

SINGLE, TWO AND THREE PHASE THYRISTOR UNITS

25 - 2700A



DIRECT INTEGRATION WITH BUS SYSTEMS & SCADA

Will converse over the most popular Buses: MODBUS, DeviceNet, PROFIBUS.



APPLICATIONS

Mesa Thyristor units are rugged and designed for industrial environment. The main applications are:

- n extruders
- n plastic machinery
- n thermoforming machinery
- n glass ovens
- n electrical furnaces
- n print machinery
- n drying process
- n car industry
- n glass industry
- n paper industry
- n infrared application
- n packaging/sealing
- n general factory automation
- n textile fiber machines
- n semiconductor
- n food/drink processing
- n chemical
- n petrochemical

NEW PRODUCT RANGE

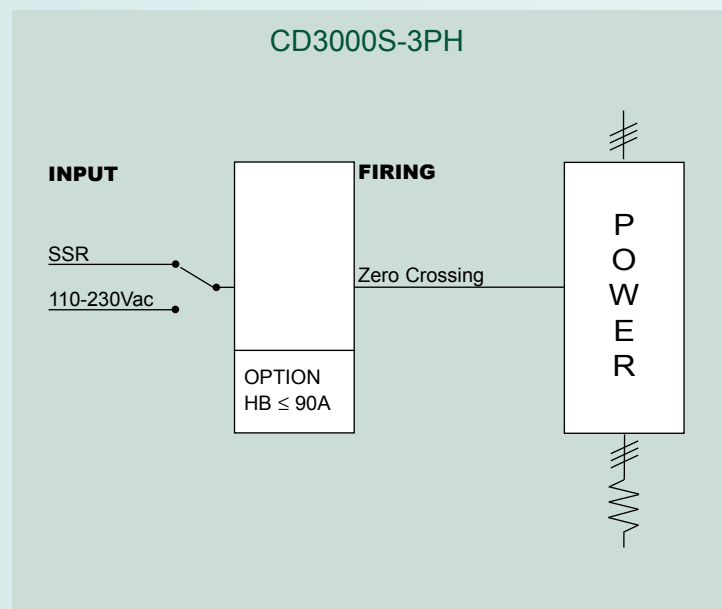
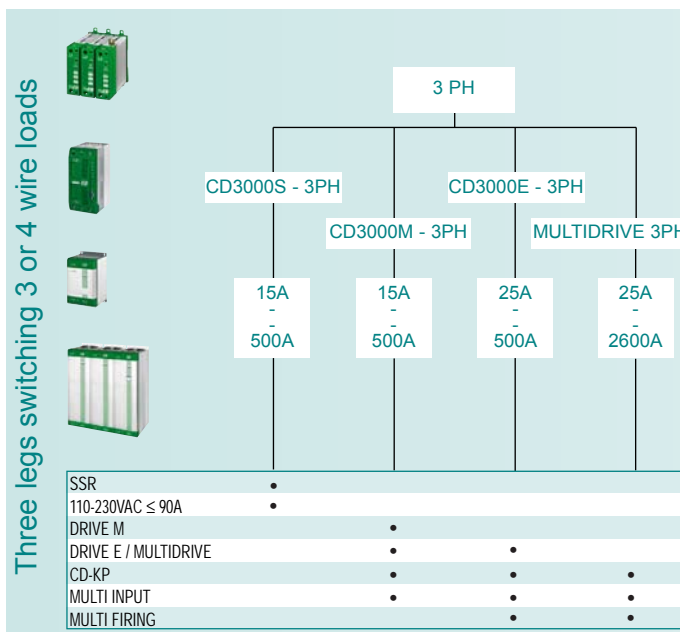
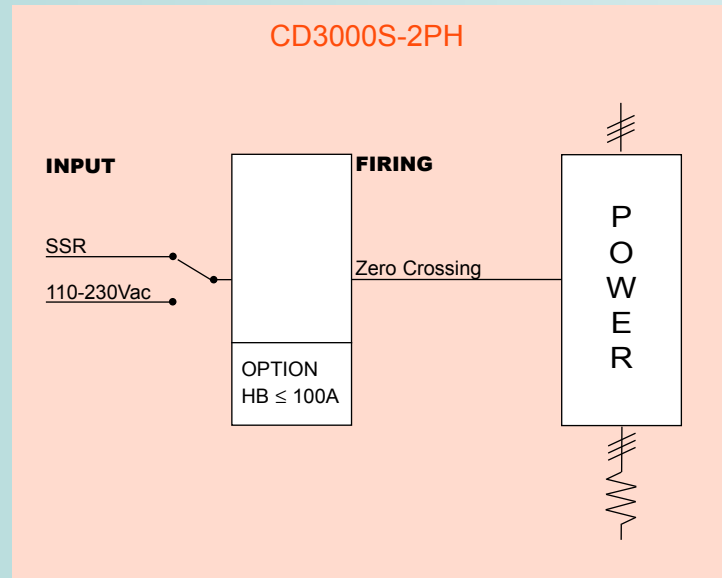
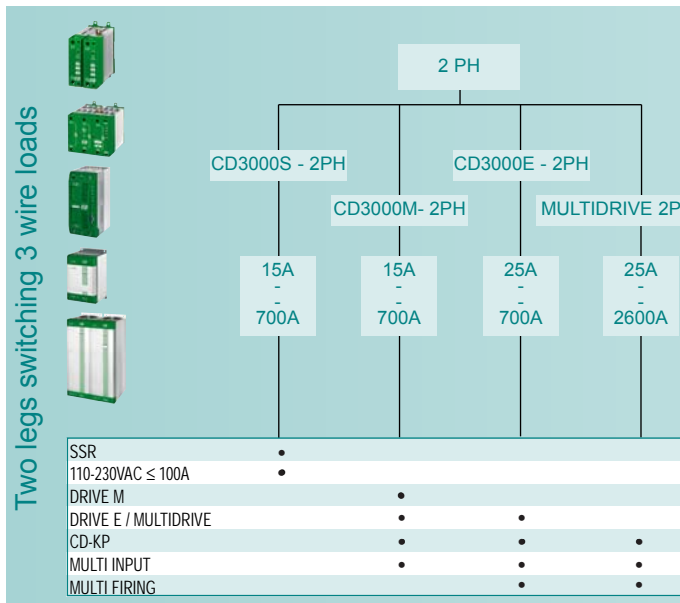
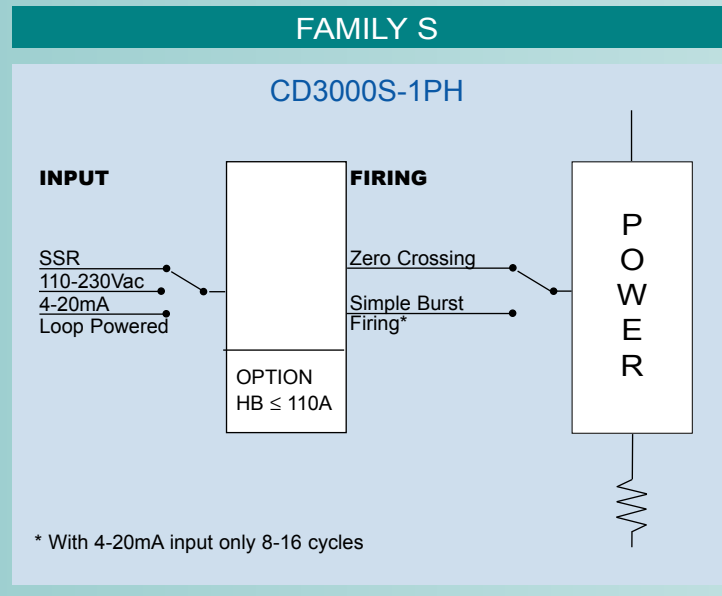
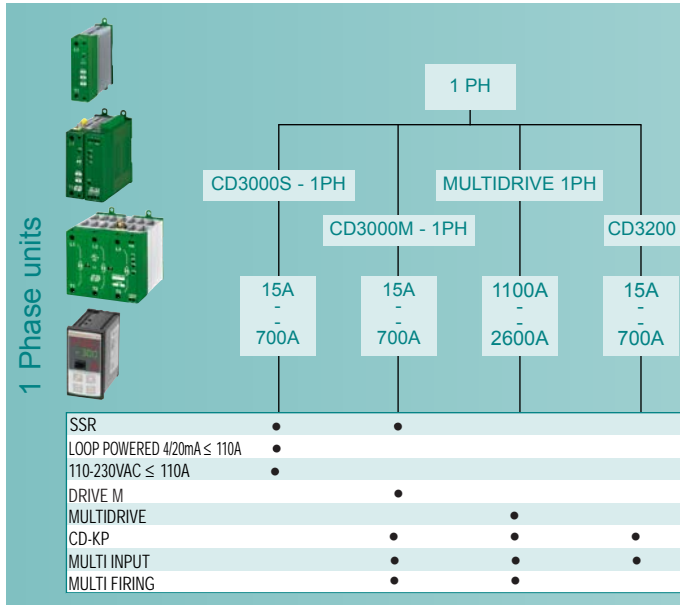

FAMILY M

CD3000M-1PH

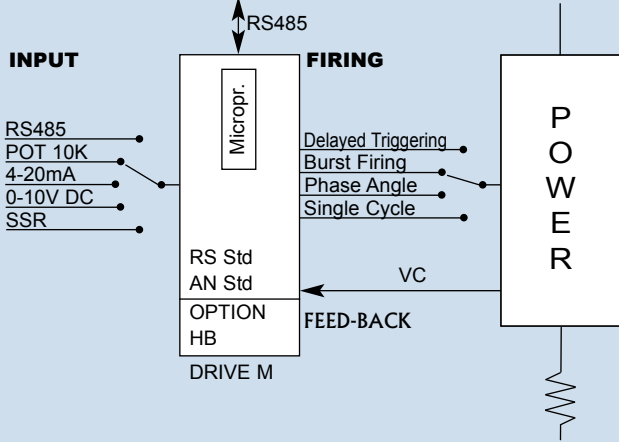

FAMILY MULTIDRIVE - CD3000E - CD3200

Multidrive-1PH - CD3200

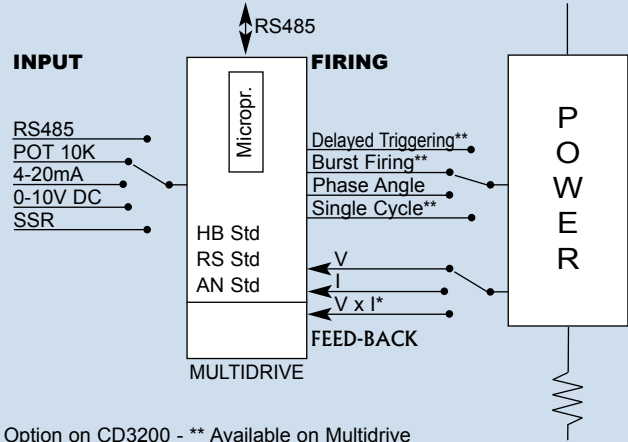

CD3000M-2PH

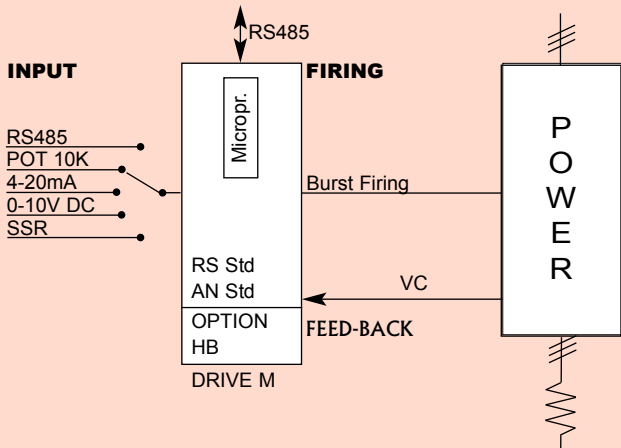

Multidrive-2PH - CD3000E-2PH

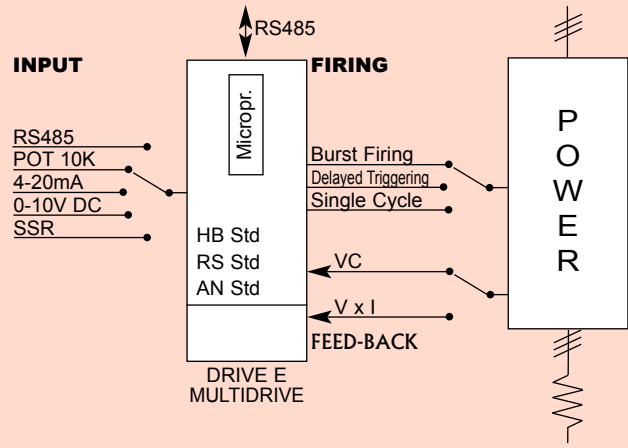

CD3000M-3PH

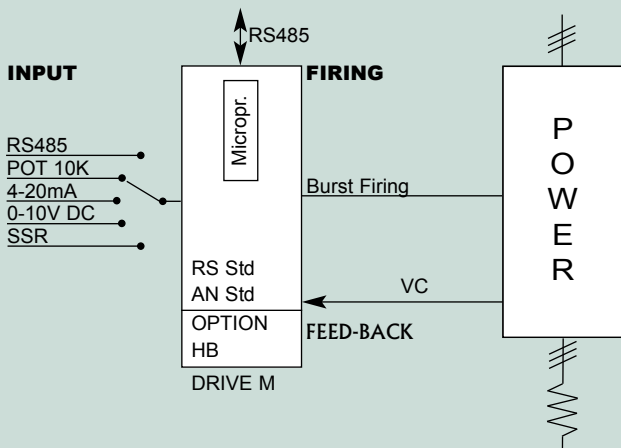

Multidrive-3PH - CD3000E-3PH

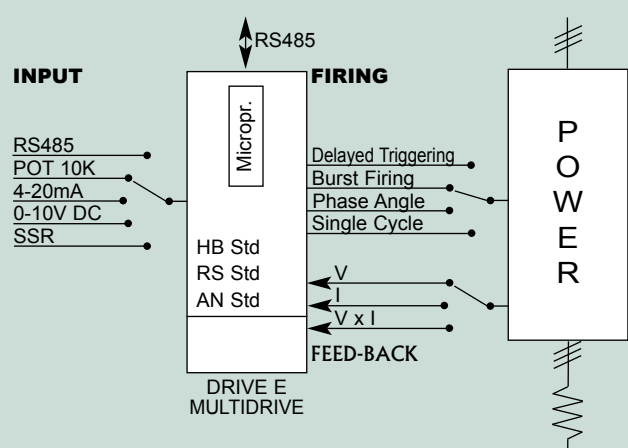

CD3000 CONFIGURATOR

- Windows based.
- Easy to use with recipe facility. Each Thyristor unit can be configured in a matter of second.
- Possibility to configure the firing mode on line without to power off the unit.
- Look for your application and download the configuration software.

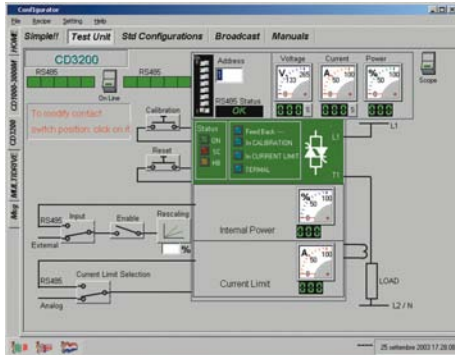

• What is a Thyristor Unit

A Thyristor unit is a semiconductor device which acts as a switch formed by two Silicon Controlled Rectifiers (SCR) in antiparallel.

To switch ON the alternating current the input signal will be ON and the Thyristor will switch OFF at first zero crossing voltage with no input signal.

The benefits of Thyristor units compared with electromechanical contactors are numerous: no moving parts, no maintenance and capacity to switch very fast.

Thyristors are the only solution to control transformers and special loads that change resistance with temperature and with age.

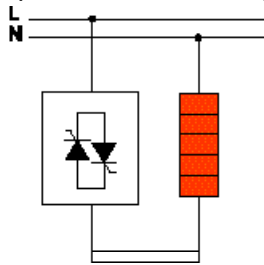

• Terminology

V: voltage between any two lines of a 3 phase supply.

I: the full circulating current in Thyristor unit.

P: total load power

• Input signal

SSR: This input type is a square waveform generated by a temperature controller. Firing of the unit is shown on right page.

AN: Analog input 4-20mA/0-10VDC.

POT: Potentiometer.

RS: Communication Command.

• AC INPUT 110 or 230V

This kind of input allows to drive the Thyristor unit by a 110 or 230Vac signal.

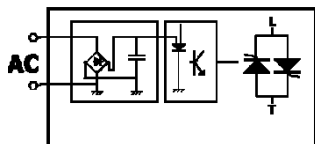

- **LP 4-20mA Loop Powered.** The voltage supply for Micro is given by 4-20mA input signal. With this input is possible to have a simple Burst Firing 8 or 16 Cycles.

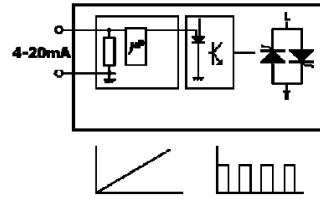

• Feedback

Supply voltage fluctuation changes the power to the load. To overcome this effect the voltage supplied to the load is measured and compared with power demand from controller. The error signal is used to automatically hold the power at demanded level. When the load changes its value it is necessary to use VxI feedback.

• Extra Features

HB: Heater Break circuit to diagnose partial or total load failure and short circuit on Thyristors. Thyristors units provide a microprocessor based circuit with automatic setting via a digital input.

CL: Current Limit to limit the current to the setted value from 0 to 100% of nominal current.

The Current Limit must be used with inductive loads, Molibdenum, Superkanthal, Platinum and Quartz lamp.

RS: RS485 two wires serial Communication with MODBUS Protocol. Thyristors units that provide this option, can communicate to a supervisory computer following data: current to the load, HB set, HB status.

• Derating Curve

The nominal current of the units in specification is referred to continuous service at 40°C or 45°C ambient temperature.

For higher temperature multiply the nominal current times derating coefficient "K" below represented.

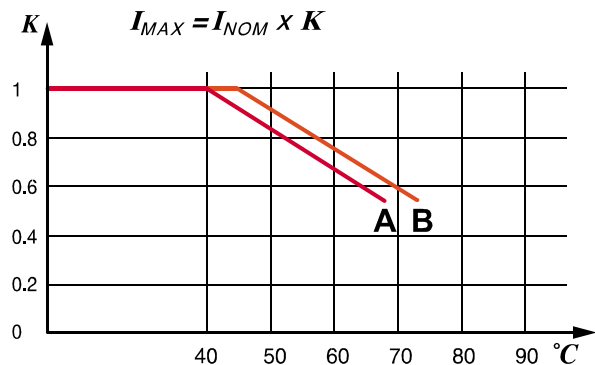

A: Use this curve for:

CD3000S-1PH and CD3000M-1PH • 110A

CD3000S-2PH and CD3000M-2PH • 100A

CD3000S-3PH and CD3000M-3PH • 90A

B: Use this curve for all products not included in the above list.

- **Zero Crossing ZC**

ZC firing mode is used with Logic Output from temperature controllers and the Thyristor operates like a contactor. The Cycle time is performed by temperature controller. Zero Crossing minimizes interferences because the Thyristor unit switches ON-OFF at zero voltage.

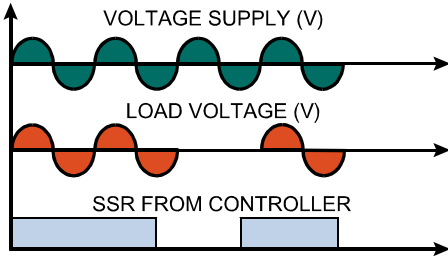

- **Burst Firing BF**

This firing performed in Digital mode in CD Automation Thyristor unit gives a lot of advantages because switches Thyristor at zero voltage crossing without EMC interferences. Analog input is necessary for BF and can be decided how many complete Cycles we want at 50% of power demand. This value can be implemented from 1 to 255 complete Cycles doing the firing less or more fast. When 1 is setted the firing name becomes Single Cycle (see below).

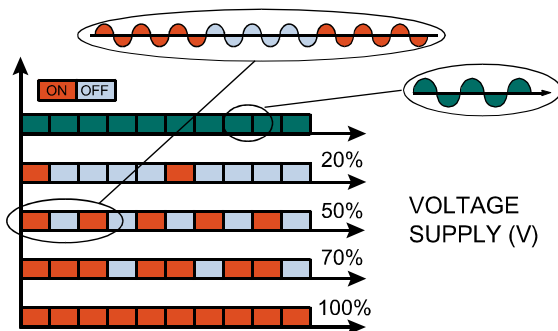

- **Single Cycle SC**

It's the fastest zero crossing switching method to respect the power demand from a temperature controller or an external signal. At 50% input signal is one cycle ON and one cycle OFF. At 75% is 3 cycles ON and one cycle OFF. If power demand is 76% the unit performs like for 75% but every time that switches ON the microprocessor divides 76/75 and when the sum of rest is one the unit deliveries one cycle more to the load. With this firing is necessary to have analog input.

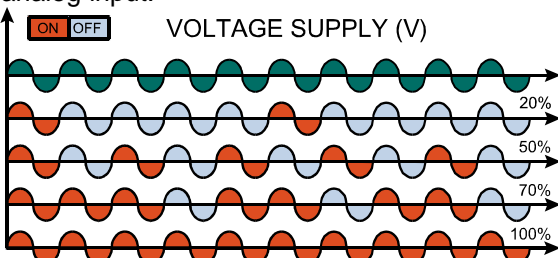

- **Delayed Triggering DT**

It's used to switch ON-OFF primary of transformers coupled with resistive load on secondary. It's used to prevent inrush surge current when zero voltage switching is used. The Thyristor unit switches OFF when load voltage is negative and switches ON only when is positive with a setted delay for the first half cycle.

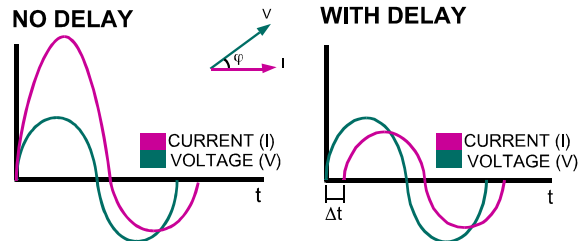

- **Phase Angle PA**

With Phase Angle is possible to control the power to the load allowing to Thyristor to be in conduction for a variable part of the voltage supply cycle. The load power can be adjusted from zero to 100% as a function of analog input signal, normally delivered by temperature controller or by potentiometer. Phase Angle is used with inductive loads.

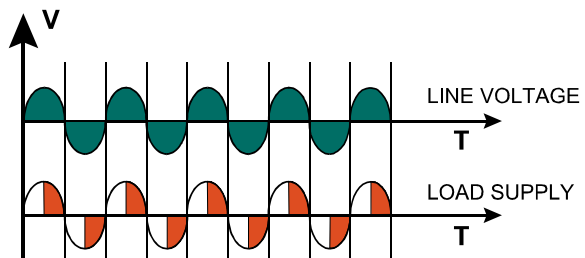

- **Soft Start+Burst Firing S+BF**

This is an additional feature to Burst Firing. The unit starts in Phase Angle mode with a ramp starting from zero up to full voltage in a presetted and adjustable time. After which the rest of ON period will be at full conduction. Soft Start+Burst Firing is used to switch ON small inductive loads to avoid inrush current and to reduce at minimum

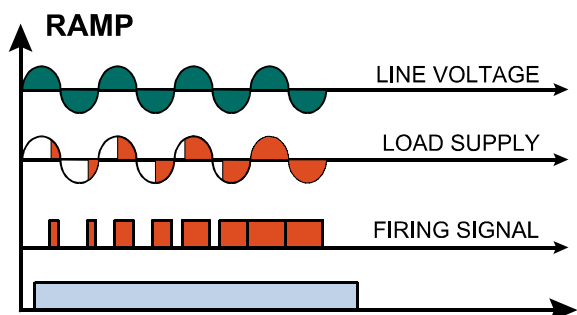

APPLICATION GUIDE

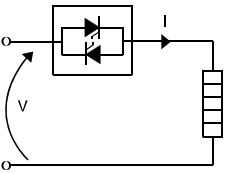
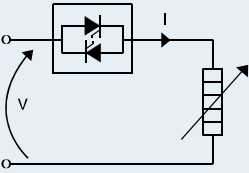
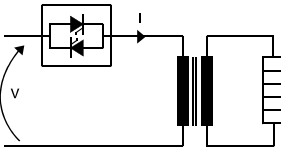
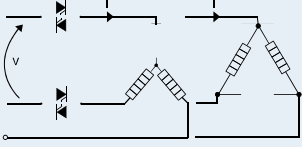
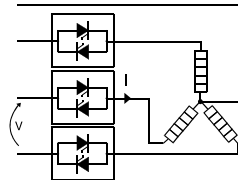
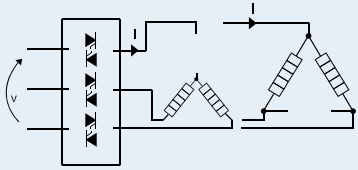
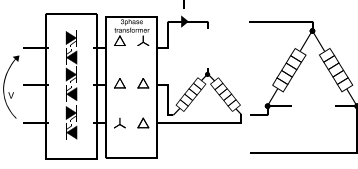
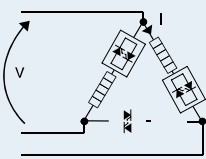
APPLICATION	LOAD TYPE	MODEL	CURRENT	N° of UNITS	CTRL. PHASES
	Normal Resistance Infrared medium and long waveform	CD3000S-1PH	700A	1	1
		MULTIDRIVE-1PH	1100+2600A	1	1
		CD3000M-1PH	700A	1	1
		CD3200	700A	1	1
	Molibdenum, Tungstenum, Superkanthal, Platinum, Quartz lamp infrared short waveform	CD3200	700A	1	1
		MULTIDRIVE-1PH	1100+2600A	1	1
	Silicon carbide elements	CD3000M-1PH	700A	1	1
		CD3200	700A	1	1
		MULTIDRIVE-1PH	1100+2600A	1	1
	Transformers and inductances	CD3000M-1PH	700A	1	1
		CD3200	700A	1	1
		MULTIDRIVE-1PH	1100+2600A	1	1
	Normal Resistance	CD3000S-2PH	700A	1	2
		CD3000M-2PH	700A	1	2
		MULTIDRIVE-2PH	1100+2600A	1	2
	Normal Resistance	CD3000S-3PH	500A	1	3
		CD3000M-3PH	500A	1	3
		MULTIDRIVE-3PH	1100+2600A	1	3
	Silicon carbide elements	CD3000E-3PH	500A	1	3
		MULTIDRIVE-3PH	1100+2600A	1	3
	Molibdenum, Tungstenum, Superkanthal, Platinum, Quartz lamp infrared short waveform	CD3000E-3PH	500A	1	3
		MULTIDRIVE-3PH	1100+2600A	1	3
	Three phase transformer	CD3000E-3PH	500A	1	3
		MULTIDRIVE-3PH	1100+2600A	1	3
	Three phase normal load resistance with open delta connection	CD3000S-3PH	500A	1	3
		CD3000M-3PH	500A	1	3
		MULTIDRIVE-3PH	1100+2600A	1	3

FEEDBACK MODE: VC = Voltage compensation - V = Voltage feedback - VxI = Power feedback.

SUGGESTED FIRING MODE FOR YOUR APPLICATION						OTHER FEATURES		SIZING		NOTE
ZC	SC	BF	S+BF	DT	PA	CL	FEEDBACK	V	I	
●								V	$\frac{P}{V}$	For general resistance applications with low variations in temperature and age. For low inertia loads use Single Cycle (SC) or Phase Angle (PA).
		●	●		●		V			
	●	●			●		VC			
					●		V	V	$\frac{P}{V}$	These resistances change with temperature but have low variations with age. Starting current with cold elements can be 16 times nominal current (superkanthal). Infrared lamp short waveform can reach 8 time nominal current.
					●	●	V			
		●						V	$\frac{P}{V}$	These resistances change value with temperature and age and value at the end of element life is 4 times the initial value. Constant power regulation is necessary. It's available an algorithm suited to drive in Single Cycle Silicon carbide elements.
					●		Vxl			
					●		Vxl			
				●			VC	V	$\frac{P}{V \cos \theta}$	Transformers and inductors have inrush current on start up. Phase Angle plus Soft Start and current limit are required. To switch ON-OFF the transformer can be used DT firing that automatically switches ON-OFF when current value is zero.
					●	●	V			
					●		V			
●								V	$\frac{P}{1.73V}$	CD3000M-2PH is suitable to control resistive loads with delta or star connection without neutral. With analog input use BF and with SSR input use ZC.
		●					VC			
		●					VC			
●								$\frac{V}{1.73}$	$\frac{P}{1.73V}$	Three phase load with star plus neutral connection must be controlled on the three phases.
		●					VC			
		●					VC			
					●		Vxl	V	$\frac{P}{1.73V}$	On three phase silicon carbide elements Vxl feedback is suggested to have a constant power control. This is necessary to compensate resistance change with temperature and age. Resistance value at the end of element life is 4 times the initial one. It's also necessary a voltage supply that is two times the nominal with new elements. It's also recommended to use SIL Algorithm to use BF firing.
					●		Vxl			
					●	●	V	V	$\frac{P}{1.73V}$	These resistances change with temperature but have low variations with age. Start up current with cold elements can be many times nominal current, thus is necessary to use Phase Angle +Current Limit (infrared short waveform).
					●	●	V			
					●	●	V	V	$\frac{P}{1.73V \cos \theta}$	Three phase Multidrive and CD30 are specially designed to drive three phase transformers coupled on secondary with normal or special resistive loads.
					●	●	V			
●								V	$\frac{P}{3V}$	Open delta can be driven by three phase unit. With analog input the units will be one Master and two Slaves.
		●					VC			
		●					VC			

PRODUCT RANGE

OVERVIEW

	CD3000S-1PH	CD3000S-2PH	CD3000S-3PH	CD3000M-1PH	CD3000M-2PH					
LOAD TYPE										
UNIT TYPE	CD3000S-1PH	CD3000S-2PH	CD3000S-3PH	CD3000M-1PH	CD3000M-2PH					
NOMINAL MAX VOLTAGE POWER SUPPLY	240*-480-600V	480-600V	480-600V	240*-480-600V	480-600V					
CURRENT RANGE	15-700A	10-700A	15-700A	15-700A	15-700A					
SINGLE PHASE	●			●						
3 PHASE LOAD DELTA or STAR NO NEUTRAL		●			●					
3 PHASE LOAD STAR WITH NEUTRAL			●							
3 PHASE LOAD OPEN DELTA			●							
SSR 0-30VDC	●	●	●	●	●					
AC INPUT 110 or 230V	up to 110A O	up to 110A O	up to 90A O							
4-20mA LOOP POWERED	≤110A O									
4-20mA				●	●					
0-10VDC				●						
POTENTIOMETER (10k)				●	●					
COMMUNICATION COMMAND				●	●					
ZERO CROSSING	●	●	●	●	●					
SINGLE CYCLE				●						
BURST FIRING				●	●					
SOFT START + BURST				●						
PHASE ANGLE				●						
DELAYED TRIGGERING				●						
UNIVERSAL FIRING				●	●					
VOLTAGE DROP COMPENSATION				●	●					
VOLTAGE or CURRENT FEEDBACK (V or I)										
POWER FEED BACK (V x I)										
INTERNAL CURRENT LIMIT										
EXTERNAL CURRENT LIMIT PROFILING										
HEATER BREAK + SHORT CIRCUIT ON SCR	up to 110A O*	up to 100A O*	up to 90A O*	O	O					
EXTERNAL FUSE AND FUSEHOLDER	≤110A	≤100A	≤90A	≤110A	≤100A					
INTERNAL FUSES	>110A	>100A	>90A	>110A	>100A					
RS485 WITH MODBUS PROTOCOL				●	●					
PROFIBUS + DEVICENET + CANBUS				TU-PB; TU-DN	TU-PB; TU-DN					
CD-KEYPAD CONNECTIVITY				●	●					
FRONTAL KEYPAD										
PERSONAL COMPUTER PROGRAMMABLE				●	●					
CURRENT (Amps)	SIZE	MARK	SIZE	MARK	SIZE	MARK	SIZE	MARK	SIZE	MARK
2x10			S0	CE			S0C	cUL/CE	S1C	cUL/CE
15	S0	cUL/CE	S1	cUL/CE	S2	cUL/CE	S0C	cUL/CE	S1C	cUL/CE
25	S0	cUL/CE	S1	cUL/CE						
30					S4	cUL/CE				
35	S3	cUL/CE	S4	cUL/CE			S3C	cUL/CE	S4C	cUL/CE
45	S3	cUL/CE	S7	cUL/CE	S6	cUL/CE	S3C	cUL/CE	S7C	cUL/CE
60	S7	cUL/CE			S8	cUL/CE	S7C	cUL/CE		
75			S8	cUL/CE	S8	cUL/CE			S8C	cUL/CE
90	S7	cUL/CE			S8	cUL/CE	S7C	cUL/CE		
100			S8	cUL/CE					S8C	cUL/CE
110	S8	cUL/CE					S8C	cUL/CE		
125	S9	cUL/CE	S9	cUL/CE	S11	cUL/CE	S9	cUL/CE	S9	cUL/CE
150	S9	cUL/CE	S9	cUL/CE	S11	cUL/CE	S9	cUL/CE	S9	cUL/CE
200	S9	cUL/CE	S10	cUL/CE			S9	cUL/CE	S10	cUL/CE
225					S13	cUL/CE				
275			S14	UL/CE					S14	cUL/CE
300	S12	cUL/CE			S14	cUL/CE	S12	cUL/CE		
350					S14	cUL/CE				
400	S12	cUL/CE	S14	cUL/CE	S14	cUL/CE	S12	cUL/CE	S14	cUL/CE
450			S14	UL/CE	S14	cUL/CE			S14	cUL/CE
500	S12	cUL/CE	S14	cUL/CE	S14	cUL/CE	S12	cUL/CE	S14	cUL/CE
600	S12	cUL/CE	S14	cUL/CE			S12	cUL/CE	S14	cUL/CE
700	S12	UL/CE	S14	UL/CE			S12	cUL/CE	S14	cUL/CE
1100										
1600										
2100										
2600										

NOTES: * no cUL Mark

Note: 1 strengthened ventilation system in cUL version

● = Standard O = option

SIZES AND DIMENSIONS



SIZE	S0	S1	S2	S3	S4
Width	30	60	92	52	117
Height	120	120	145	120	120
Depth	120	120	120	120	123



SIZE	S0C	S1C	S2C	S3C	S4C
Width	63	95	123	85	148
Height	120	120	145	120	120
Depth	120	120	120	120	123



SIZE	S11	S12	S13	S14
Width	137	137	262	262
Height	440	520	440	520
Depth	270	270	270	270



S5	S6	S7	S8	S9
117	117	117	117	116
150	138	120	138	316
123 (159)	123	159	159	187



S6C	S7C	S8C	S10C
148	148	148	116
138	120	138	350
123	159	159	220



S15	S16	S17
300	600	900
920	920	920
410	410	410

INDUSTRIAL THYRISTOR PACKAGE

CD1000 Thyristor Unit

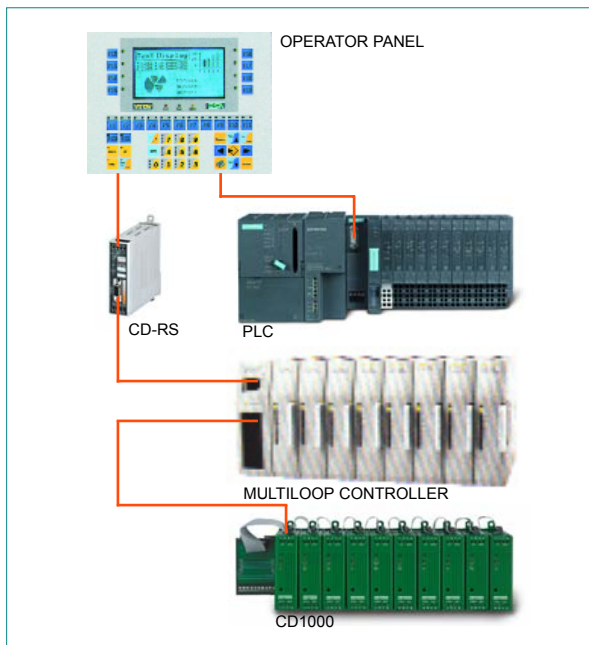

Mesa Thyristor units can be divided in two categories.

General purpose Thyristor units suitable to be used in all processes and “industrial package”, like CD1000, dedicated to a specific process. CD1000 is normally used where there are many zones: coextrusion, blow moulding and thermoforming machineries.

Target and typical architecture are represented in this page.

- Dramatic reduction of wiring. The connection between HMI and Thyristor Units is done via RS485 comm..
- Wiring between Thyristor Units is done with flat cables and connectors to avoid to make traditional wiring for auxiliary voltage supply, RS485 comm. and HB alarm. Customer has to wire only input/output power cables.
- All commands and informations are available on RS485 like load status and current value. It's also possible to set the power output of Thyristor unit using analog input or digital command on comm. port.

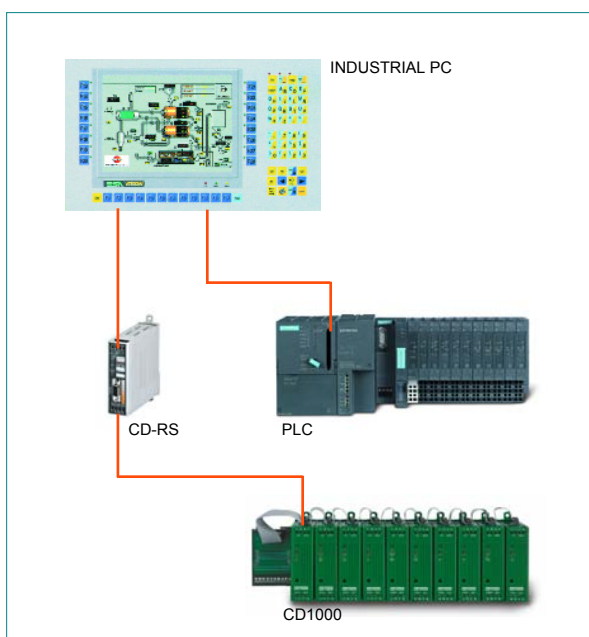

Specification

- CD1000 is a digital and universal Thyristor unit configurable via serial communication port for different types of input and firing modes.
- RS485 communication and HB alarm are standard features. Current transformer is included in 3.5A model, for other models is mounted outside.
- Universal input and firing are customer configurable via serial port. Single Cycle, Burst Firing and Phase Angle can be configured adding also Soft Start facility. The change from one to the other firing can be done via serial port with CD1000 in ON condition.
- Current rating: 3.5 - 15 - 25 - 35 - 45 - 60 - 90 - 110A

FUSES AND FUSEHOLDERS

High speed fuses for semi-conductor protection.



SIZE	F0	F1	F2	F3
Width	17	26	35	37
Height	80	110	125	150
Depth	60	77	77	107

Fuse & Fuseholder Selection TAB	Models		CD1000 CD3000S CD3000M CD3200		CD3000S-2PH CD3000M-2PH		CD3000S-3PH CD3000M-3PH		CD3000E		MULTIDRIVE	
	Current	Size	(1 off)	(each phase)	(3 off)	(each phase)	(3 off)	(each phase)	(each phase)	(each phase)	(each phase)	(each phase)
			Fuse+Fuseholder	Spare fuses	Fuse+Fuseholder	Spare fuses	Fuse+Fuseholder	Spare fuses	Spare fuses	Spare fuses	Spare fuses	Spare fuses
3.5A	F0	FFH1038/8A	FU1038/8A									
2X10A	F0	FFH1038/16A	FU1038/16A	FFH1038/16A	FU1038/16A							
15A	F0	FFH1038/16A	FU1038/16A	FFH1038/16A	FU1038/16A							
25A	F0	FFH1038/32A	FU1038/32A	FFH1038/32A	FU1038/32A				FU50FE	FU50FE	FU50FE	FU50FE
30A	F1							FFH1451/40A	FU1451/40A			
35A	F1	FFH1451/40A	FU1451/40A	FFH1451/40A	FU1451/40A				FU63FE	FU63FE		
45A	F1	FFH1451/50A	FU1451/50A	FFH1451/63A	FU1451/63A			FFH1451/50A	FU1451/50A	FU80FE	FU80FE	FU80FE
60A	F2	FFH2258/80A	FU2258/80A					FFH2258/80A	FU2258/80A			
75A	F2			FFH2258/100A	FU2258/100A			FFH2258/100A	FU2258/100A	FU100FE	FU100FE	FU100FE
90A	F2	FFH2258/125A	FU2258/125A					FFH2258/125A	FU2258/125A			
100A	F2			FFH2258/125A	FU2258/125A					FU160FEE	FU2x80FE	FU160FE
110A	F3	FFHPSI27/160A	FU2760/160A									
125A	IF	IF	FU200FEE	IF	FU200FEE	IF	FU2X100FE	IF	FU2X100FE	FU200FEE	FU2x100FE	FU200FEE
150A	IF	IF	FUURB250 or FU200FEE	IF	FUURB250 or FU200FEE	IF	FUURB250 or FU200FEE	IF	FUURB250 or FU200FEE	FUURB250 or FU200FEE	FU2x100FE	FUURB250 or FU200FEE
200A	IF	IF	FUURB315	IF	FUURB315	IF	FUURB315	IF	FUURB315	FUURB315		FUURB315 or 2xFEE160
225A	IF							IF	FUURB315 or 2xFEE160			FUURB315 or 2xFEE160
275A	IF					IF	FUURB315 or 2xFEE160			FUURB315 or 2xFEE160		FUURB315 or 2xFEE160
300A	IF	IF	FU350FMM					IF	FU450FMM			FU450FMM
350A	IF							IF	FU550FMM			FU550FMM
400A	IF	IF	FU550FMM	IF	FU550FMM	IF	FU550FMM	IF	FU550FMM	FU550FMM	FU550FMM	FU550FMM
450A	IF			IF	2xFU315FM	IF	2xFU315FM	IF	2xFU315FM or FU700FMM	2xFU315FM	2xFU315FM or FU700FMM	2xFU315FM or FU700FMM
500A	IF	IF	FU700FMM	IF	2xFU315FM	IF	2xFU315FM	IF	2xFU315FM or FU700FMM	2xFU315FM	2xFU315FM or FU700FMM	2xFU315FM or FU700FMM
600A	IF	IF	2xFU450FMM	IF	2xFU450FMM	IF	2xFU450FMM			2xFU450FMM		2xFU450FMM
700A	IF	IF	2xFU450FMM	IF	2xFU450FMM	IF	2xFU450FMM			2xFU450FMM		2xFU450FMM

Fuse & Fuseholder Selection TAB	Models cULus approved		CD 1000 CD3000S CD3000M CD3200		CD3000S-2PH CD3000M-2PH		CD3000S-3PH CD3000M-3PH		CD3000E		MULTIDRIVE	
	Current	Size	(1 off)	(each phase)	(3 off)	(each phase)	(3 off)	(each phase)	(each phase)	(each phase)	(each phase)	(each phase)
			Fuse+Fuseholder	Spare fuses	Fuse+Fuseholder	Spare fuses	Fuse+Fuseholder	Spare fuses	Spare fuses	Spare fuses	Spare fuses	Spare fuses
3.5A	F0	FFH1038/8A-UL	FU1038/8A-UL									
2X10A	F0	FFH1038/16A-UL	FU1038/16A-UL	FFH1038/16A-UL	FU1038/16A-UL							
15A	F0	FFH1038/16A-UL	FU1038/16A-UL	FFH1038/16A-UL	FU1038/16A-UL			FFH1038/16A-UL	FU1038/16A-UL			
25A	F0	FFH1038/32A-UL	FU1038/32A-UL	FFH1038/32A-UL	FU1038/32A-UL					FU50FE	FU50FE	FU50FE
30A	F1							FFH1451/40A-UL	FU1451/40A-UL			
35A	F1	FFH1451/40A-UL	FU1451/40A-UL	FFH1451/40A-UL	FU1451/40A-UL					FU63FE	FU63FE	
45A	F1	FFH1451/50A-UL	FU1451/50A-UL	FFH1451/63A-UL	FU1451/63A-UL			FFH1451/50A-UL	FU1451/50A-UL	FU80FE	FU80FE	FU80FE
60A	F2	FFH2258/80A-UL	FU2258/80A-UL					FFH2258/80A-UL	FU2258/80A-UL			
75A	F3			FFHPSI27/100A-UL	FU2760/100A-UL			FFHPSI27/100A-UL	FU2760/100A-UL	FU100FE	FU100FE	FU100FE
90A	F3	FFHPSI27/125A-UL	FU2760/125A-UL					FFHPSI27/125A-UL	FU2760/125A-UL			
100A	F3			FFHPSI27/160A-UL	FU2760/160A-UL					FU160FEE	FU2x80FE	FU160FEE
110A	F3	FFHPSI27/160A-UL	FU2760/160A-UL									
125A	IF	IF	FU200FEE	IF	FU200FEE	IF	FU2X100FE	IF	FU2X100FE	FU200FEE	FU2x100FE	FU200FEE
150A	IF	IF	FUURB250 or FU200FEE	IF	FUURB250 or FU200FEE	IF	FUURB250 or FU200FEE	IF	FUURB250 or FU200FEE	FUURB250 or FU200FEE	FU2x100FE	FUURB250 or FU200FEE
200A	IF	IF	FUURB315	IF	FUURB315	IF	FUURB315	IF	FUURB315	FUURB315		FUURB315 or 2xFEE160
225A	IF							IF	FUURB315 or 2xFEE160			FUURB315 or 2xFEE160
275A	IF					IF	FUURB315 or 2xFEE160			FUURB315 or 2xFEE160		FUURB315 or 2xFEE160
300A	IF	IF	FU350FMM					IF	FU450FMM			FU450FMM
350A	IF							IF	FU550FMM			FU550FMM
400A	IF	IF	FU550FMM	IF	FU550FMM	IF	FU550FMM	IF	FU550FMM	FU550FMM	FU550FMM	FU550FMM
450A	IF			IF	2xFU315FM	IF	2xFU315FM	IF	2xFU315FM or FU700FMM	2xFU315FM	2xFU315FM or FU700FMM	2xFU315FM or FU700FMM
500A	IF	IF	FU700FMM	IF	2xFU315FM	IF	2xFU315FM	IF	2xFU315FM or FU700FMM	2xFU315FM	2xFU315FM or FU700FMM	2xFU315FM or FU700FMM
600A	IF	IF	2xFU450FMM	IF	2xFU450FMM	IF	2xFU450FMM			2xFU450FMM		2xFU450FMM
700A	IF	IF	2xFU450FMM	IF	2xFU450FMM	IF	2xFU450FMM			2xFU450FMM		2xFU450FMM

NOTES: IF = internal fuses, FFH = external fuse+fuseholder.

In accordance with our policy of continuous improvement, CD Automation reserves the right to change specifications from those shown in this document.



Mesa Industrie-Elektronik GmbH
Neckarstraße 19
D-45768 Marl
Tel +49 (0) 2365 97451 -0
Fax +49 (0) 2365 97451-25
info@mesa-gmbh.de